

VALVE CLEARANCE INSPECTION

EM02K-04

HINT:

Inspect and adjust the valve clearance when the engine is cold.

1. **REMOVE INTAKE AIR CONNECTOR** (See page [EM-34](#))
2. **REMOVE PCV HOSES**
3. **REMOVE IGNITION COILS (WITH IGNITER)**
4. **DISCONNECT ENGINE WIRE**
 - (a) w/ A/C:
Disconnect the A/C compressor connector.
 - (b) Disconnect the oil pressure sensor connector.
 - (c) Disconnect the ECT sender gauge connector.
 - (d) Disconnect the 4 engine wire clamps and engine wire.

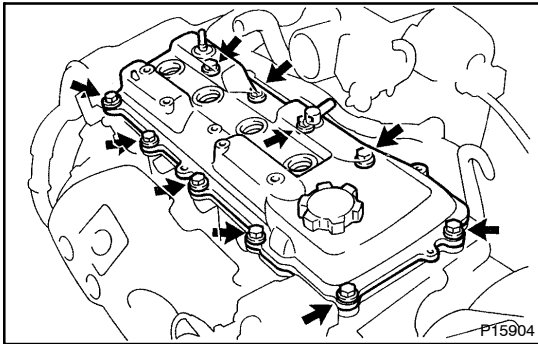

5. REMOVE CYLINDER HEAD COVER

Remove the 10 bolts, 10 seal washers, cylinder head cover and gasket.

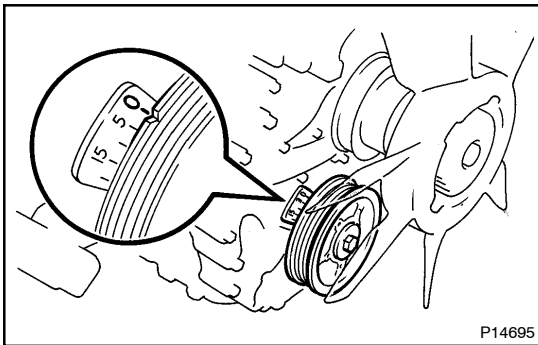

6. SET NO.1 CYLINDER TO TDC/COMPRESSION

- (a) Turn the crankshaft pulley clockwise and align its groove with the "0" mark on the timing chain cover.

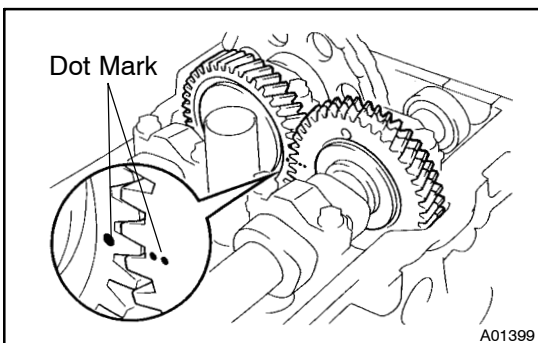

- (b) Check that the timing marks (1 and 2 dots) of the camshaft drive and driven gears are in straight line on the cylinder head surface as shown in the illustration. If not, turn the crankshaft 1 revolution (360°) and align the marks as above.

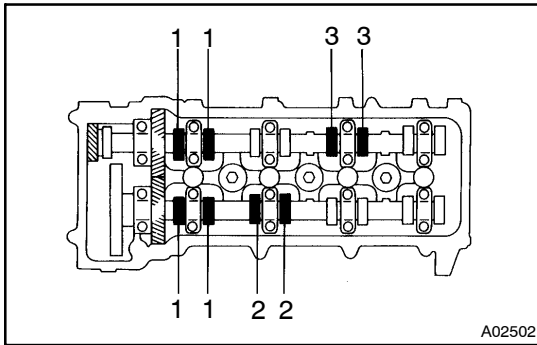

7. INSPECT VALVE CLEARANCE

- (a) Check only the valves indicated.
- (1) Using a feeler gauge, measure the clearance between the valve lifter and camshaft.
 - (2) Record the out-of-specification valve clearance measurements. They will be used later to determine the required replacement adjusting shim.

Valve clearance (Cold):

Intake	0.15 – 0.25 mm (0.006 – 0.010 in.)
Exhaust	0.25 – 0.35 mm (0.010 – 0.014 in.)

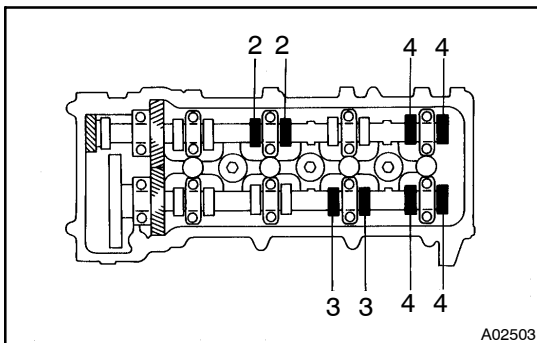

- (b) Turn the crankshaft pulley 1 revolution (360°) and align its groove with timing mark "0" of the timing chain cover.
- (c) Check only the valves indicated as shown. Measure the valve clearance (See procedure in step (a)).

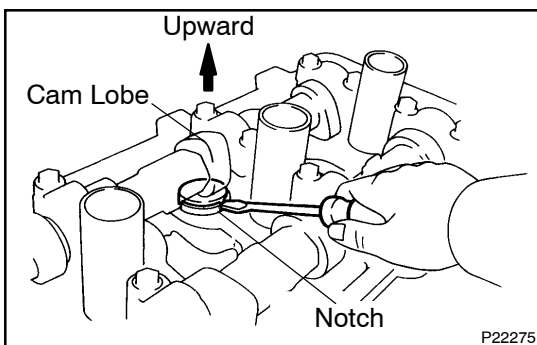

8. ADJUST VALVE CLEARANCE

- (a) Remove the adjusting shim.
- (1) Turn the crankshaft to position the cam lobe of the camshaft on the adjusting valve upward.
 - (2) Position the notch of the valve lifter toward the spark plug side.

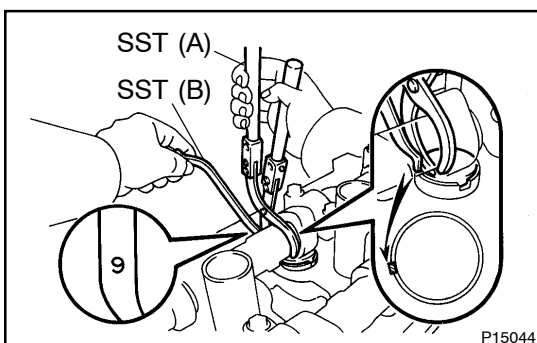

- (3) Using SST (A), press down the valve lifter and place SST (B) between the camshaft and valve lifter flange. Remove SST (A).

SST 09248-55040 (09248-05410, 09248-05420)

HINT:

Apply SST (B) at slight angle on the side marked with "9", at the position shown in the illustration.

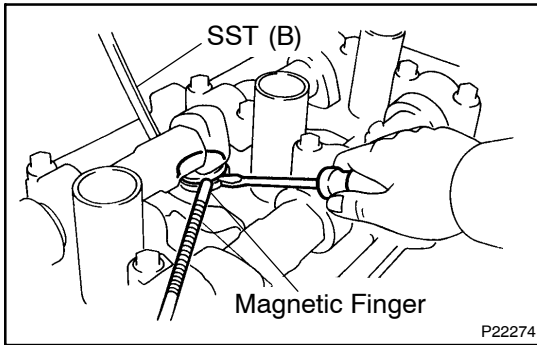

- (4) Remove the adjusting shim with a small screwdriver and magnetic finger.

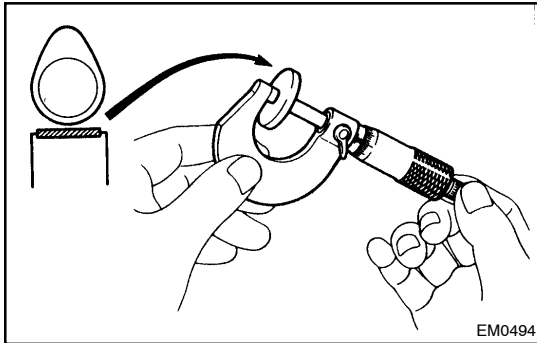

- (b) Determine the replacement adjusting shim size by these Formula or Charts:

- (1) Using a micrometer, measure the thickness of the removed shim.
- (2) Calculate the thickness of a new shim so that the valve clearance comes within the specified value.

T Thickness of removed shim

A Measured valve clearance

N Thickness of new shim

Intake: $N = T + (A - 0.20 \text{ mm (0.008 in.)})$

Exhaust: $N = T + (A - 0.30 \text{ mm (0.012 in.)})$

- (3) Select a new shim with a thickness as close as possible to the calculated value.

HINT:

Shims are available in 17 sized in increments of 0.05 mm (0.0020 in.), from 2.50 mm (0.0984 in.) to 3.30 mm (0.1299 in.).

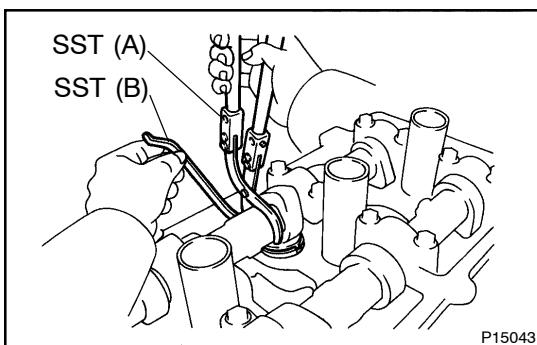

- (c) Install a new adjusting shim.
- (1) Place a new adjusting shim on the valve lifter.
 - (2) Using SST (A), press down the valve lifter and remove SST (B).

SST 09248-55040 (09248-05410, 09248-05420)

- (d) Recheck the valve clearance.

9. REINSTALL CYLINDER HEAD COVER

10. RECONNECT ENGINE WIRE

11. REINSTALL HIGH-TENSION CORDS TO SPARK-PLUGS

12. REINSTALL PCV HOSES

13. REINSTALL INTAKE AIR CONNECTOR (See page [EM-57](#))

Adjusting Shim Selection Chart (Intake)

Measured clearance mm (in.)	Installed shim thickness mm (in.)	New shim thickness mm (in.)																
		Shim No.	Thickness	Shim No.	Thickness	Shim No.	Thickness	Shim No.	Thickness	Shim No.	Thickness	Shim No.	Thickness	Shim No.	Thickness	Shim No.	Thickness	
0.000 - 0.030 (0.0000 - 0.0012)		1	1	1	1	1	1	1	1	1	1	1	1	1	1	1	1	
0.031 - 0.050 (0.0012 - 0.0020)		1	1	1	1	1	1	1	1	1	1	1	1	1	1	1	1	
0.051 - 0.070 (0.0020 - 0.0028)		1	1	1	1	1	1	1	1	1	1	1	1	1	1	1	1	
0.071 - 0.090 (0.0028 - 0.0035)		1	1	1	1	1	1	1	1	1	1	1	1	1	1	1	1	
0.091 - 0.110 (0.0036 - 0.0043)		1	1	1	1	1	1	1	1	1	1	1	1	1	1	1	1	
0.111 - 0.130 (0.0044 - 0.0051)		1	1	1	1	1	1	1	1	1	1	1	1	1	1	1	1	
0.131 - 0.149 (0.0052 - 0.0059)		1	1	1	1	1	1	1	1	1	1	1	1	1	1	1	1	
0.150 - 0.250 (0.0059 - 0.0098)		2	3	3	3	3	3	3	3	3	3	3	3	3	3	3	3	
0.251 - 0.270 (0.0099 - 0.0106)		2	3	3	3	3	3	3	3	3	3	3	3	3	3	3	3	
0.271 - 0.290 (0.0107 - 0.0114)		3	3	3	3	3	3	3	3	3	3	3	3	3	3	3	3	
0.291 - 0.310 (0.0115 - 0.0122)		3	3	3	3	3	3	3	3	3	3	3	3	3	3	3	3	
0.311 - 0.330 (0.0122 - 0.0130)		3	3	3	3	3	3	3	3	3	3	3	3	3	3	3	3	
0.331 - 0.350 (0.0130 - 0.0138)		4	4	4	4	4	4	4	4	4	4	4	4	4	4	4	4	
0.351 - 0.370 (0.0138 - 0.0146)		4	4	4	4	4	4	4	4	4	4	4	4	4	4	4	4	
0.371 - 0.390 (0.0146 - 0.0154)		5	5	5	5	5	5	5	5	5	5	5	5	5	5	5	5	
0.391 - 0.410 (0.0154 - 0.0161)		5	5	5	5	5	5	5	5	5	5	5	5	5	5	5	5	
0.411 - 0.430 (0.0162 - 0.0169)		5	5	5	5	5	5	5	5	5	5	5	5	5	5	5	5	
0.431 - 0.450 (0.0170 - 0.0177)		6	6	6	6	6	6	6	6	6	6	6	6	6	6	6	6	
0.451 - 0.470 (0.0178 - 0.0185)		6	6	6	6	6	6	6	6	6	6	6	6	6	6	6	6	
0.471 - 0.490 (0.0185 - 0.0193)		7	7	7	7	7	7	7	7	7	7	7	7	7	7	7	7	
0.491 - 0.510 (0.0193 - 0.0201)		7	7	7	7	7	7	7	7	7	7	7	7	7	7	7	7	
0.511 - 0.530 (0.0201 - 0.0209)		8	8	8	8	8	8	8	8	8	8	8	8	8	8	8	8	
0.531 - 0.550 (0.0209 - 0.0217)		8	8	8	8	8	8	8	8	8	8	8	8	8	8	8	8	
0.551 - 0.570 (0.0217 - 0.0224)		8	8	8	8	8	8	8	8	8	8	8	8	8	8	8	8	
0.571 - 0.590 (0.0225 - 0.0232)		9	9	9	9	9	9	9	9	9	9	9	9	9	9	9	9	
0.591 - 0.610 (0.0233 - 0.0240)		9	9	9	9	9	9	9	9	9	9	9	9	9	9	9	9	
0.611 - 0.630 (0.0241 - 0.0248)		10	10	10	10	10	10	10	10	10	10	10	10	10	10	10	10	
0.631 - 0.650 (0.0248 - 0.0256)		10	10	10	10	10	10	10	10	10	10	10	10	10	10	10	10	
0.651 - 0.670 (0.0256 - 0.0264)		10	10	10	10	10	10	10	10	10	10	10	10	10	10	10	10	
0.671 - 0.690 (0.0264 - 0.0272)		11	11	11	11	11	11	11	11	11	11	11	11	11	11	11	11	
0.691 - 0.710 (0.0272 - 0.0280)		11	11	11	11	11	11	11	11	11	11	11	11	11	11	11	11	
0.711 - 0.730 (0.0280 - 0.0288)		12	12	12	12	12	12	12	12	12	12	12	12	12	12	12	12	
0.731 - 0.750 (0.0288 - 0.0295)		12	12	12	12	12	12	12	12	12	12	12	12	12	12	12	12	
0.751 - 0.770 (0.0296 - 0.0303)		12	12	12	12	12	12	12	12	12	12	12	12	12	12	12	12	
0.771 - 0.790 (0.0304 - 0.0311)		13	13	13	13	13	13	13	13	13	13	13	13	13	13	13	13	
0.791 - 0.810 (0.0311 - 0.0319)		13	13	13	13	13	13	13	13	13	13	13	13	13	13	13	13	
0.811 - 0.830 (0.0319 - 0.0327)		14	14	14	14	14	14	14	14	14	14	14	14	14	14	14	14	
0.831 - 0.850 (0.0327 - 0.0335)		14	14	14	14	14	14	14	14	14	14	14	14	14	14	14	14	
0.851 - 0.870 (0.0335 - 0.0343)		14	14	14	14	14	14	14	14	14	14	14	14	14	14	14	14	
0.871 - 0.890 (0.0343 - 0.0350)		15	15	15	15	15	15	15	15	15	15	15	15	15	15	15	15	
0.891 - 0.910 (0.0351 - 0.0358)		15	15	15	15	15	15	15	15	15	15	15	15	15	15	15	15	
0.911 - 0.930 (0.0359 - 0.0366)		16	16	16	16	16	16	16	16	16	16	16	16	16	16	16	16	
0.931 - 0.950 (0.0367 - 0.0374)		16	16	16	16	16	16	16	16	16	16	16	16	16	16	16	16	
0.951 - 0.970 (0.0374 - 0.0382)		16	16	16	16	16	16	16	16	16	16	16	16	16	16	16	16	
0.971 - 0.990 (0.0382 - 0.0390)		17	17	17	17	17	17	17	17	17	17	17	17	17	17	17	17	
0.991 - 1.010 (0.0390 - 0.0398)		17	17	17	17	17	17	17	17	17	17	17	17	17	17	17	17	
1.011 - 1.030 (0.0398 - 0.0406)		17	17	17	17	17	17	17	17	17	17	17	17	17	17	17	17	
1.031 - 1.050 (0.0406 - 0.0413)		17	17	17	17	17	17	17	17	17	17	17	17	17	17	17	17	

Intake valve clearance (Cold):
0.15 - 0.25 mm (0.006 - 0.010 in.)
EXAMPLE:
 The 2.800 mm (0.1102 in.) shim is installed,
 and the measured clearance is 0.440 mm
 (0.0173 in.). Replace the 2.800 mm
 (0.1102 in.) shim with a new No.12 shim.

HINT:
 New shims have the thickness in millimeters imprinted on the face.

