

Eaton Solo Advantage® Heavy-Duty Clutch Reset Tool CLMT1307

February 2012

Copyright Eaton Corporation, 2012. Eaton hereby grants their customers, vendors, or distributors permission to freely copy, reproduce and/or distribute this document in printed format. It may be copied only in its entirety without any changes or modifications. THIS INFORMATION IS NOT INTENDED FOR SALE OR RESALE, AND THIS NOTICE MUST REMAIN ON ALL COPIES.

Note: Features and specifications listed in this document are subject to change without notice and represent the maximum capabilities of the software and products with all options installed. Although every attempt has been made to ensure the accuracy of information contained within, Eaton makes no representation about the completeness, correctness or accuracy and assumes no responsibility for any errors or omissions. Features and functionality may vary depending on selected options.

For spec'ing or service assistance, call 1-800-826-HELP (4357) or visit www.eaton.com/roadranger. In Mexico, call 001-800-826-4357.

Roadranger: Eaton and trusted partners providing the best products and services in the industry, ensuring more time on the road.

Eaton Corporation
Vehicle Group
P.O. Box 4013
Kalamazoo, MI 49003 USA
800-826-HELP (4357)
www.eaton.com/roadranger

Printed in USA



BACKED BY
Roadranger
SUPPORT

Use tool during resetting procedure to move cam to New position.

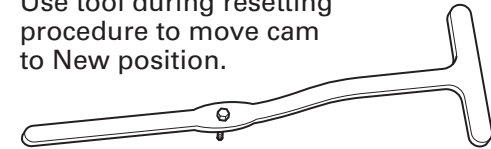

Tool Part Code:
RR1005CL

- 1** Measure distance between release bearing and clutch brake.

If measurement is not between 0.490" and 0.560", reset clutch. Go to step 2.

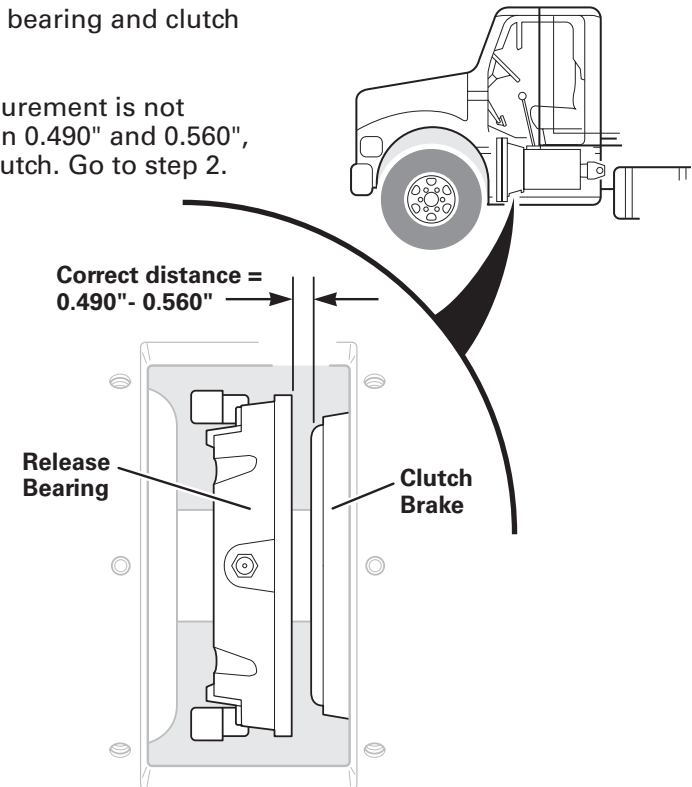

BACKED BY
Roadranger
SUPPORT

- 2** If cam does not move, loosen transmission and install 1/2" spacers between clutch housing and engine housing to increase stroke.

With spacers in place:

- Have assistant hold clutch pedal down
- Use tool to move cam to New position
- Release clutch pedal

Remove spacers and torque transmission mounting bolts.

- 3** Have assistant hold clutch pedal down.

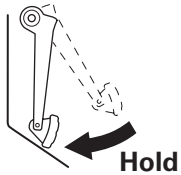

- 4** Position tool:
- Through access panel
 - Under release bearing
 - Threaded bolt in cam slot

- 5** Use tool to move cam to New position.



- 6** Release clutch pedal.

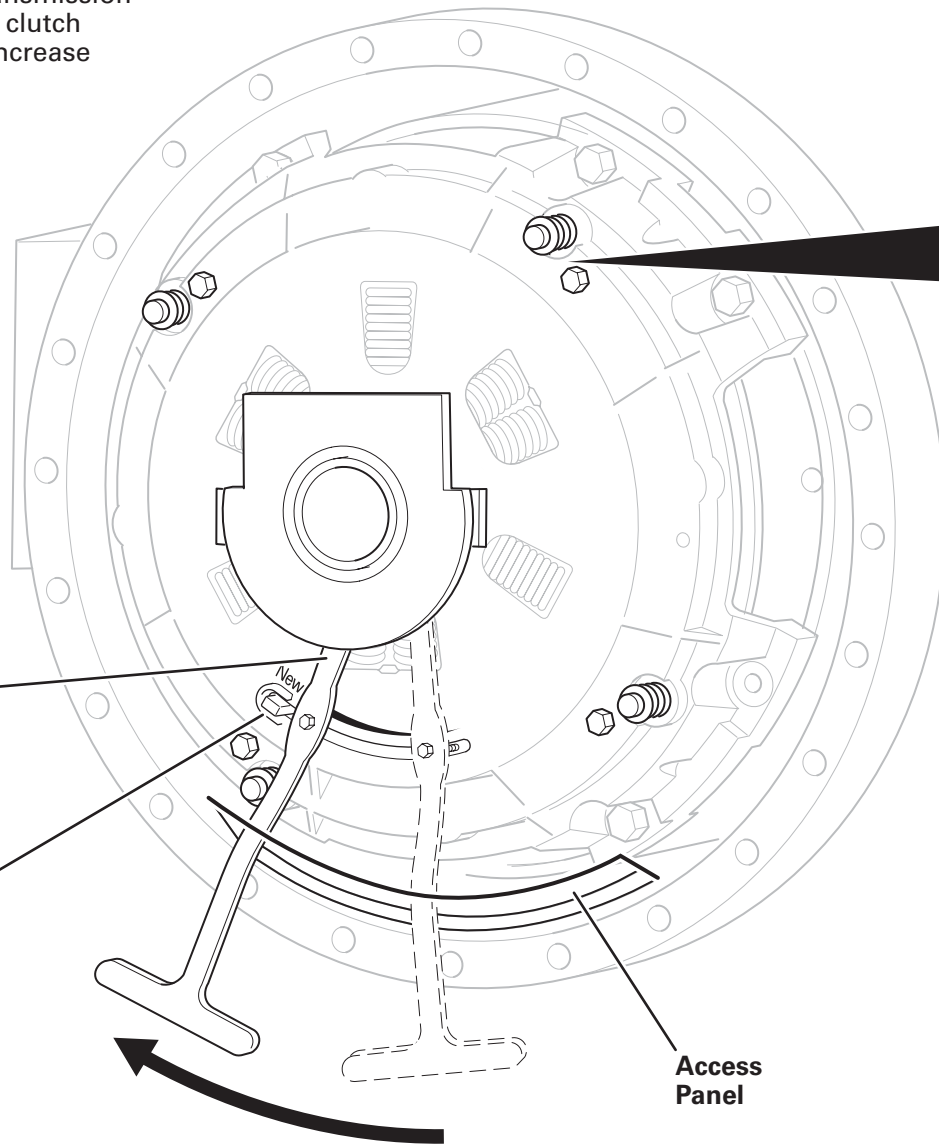

- 7** Install and tighten 4 shipping bolts (7/16" x 14 x 1-3/4 UNC) to remove gap between sleeve and pin.

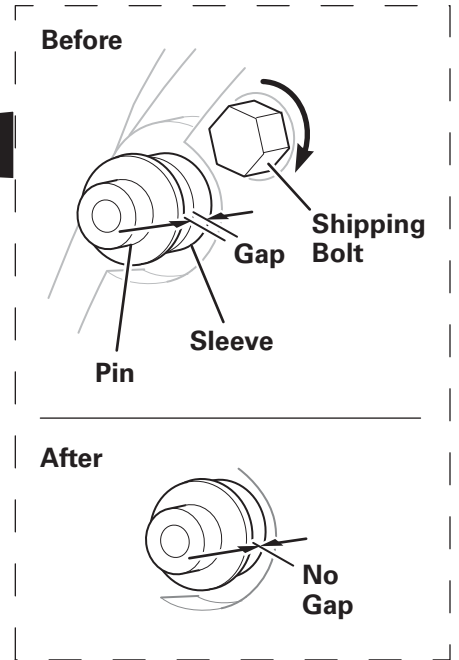

- 8** Remove 4 shipping bolts.

- 9** Push pedal down and squeeze clutch brake 5 times to reposition bearing.

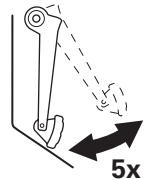

- 10** Verify reset. Go to step 1.