

## Transaxle Range (TR) Switch Removal/Installation [FN4 A EL]

[Report a problem with this article](#)

### Applies to:

FN4\_A\_EL

### 2009 - Mazda3 - Transmission/Transaxle

#### TRANSAXLE RANGE (TR) SWITCH REMOVAL/INSTALLATION [FN4A-EL]

1. Remove the battery duct and battery cover. (See [BATTERY REMOVAL/INSTALLATION \[LF, L3\]](#).)
2. Disconnect the negative battery cable.
3. Remove the under cover.

#### CAUTION:

- Water or foreign material entering the connector can cause a poor connection or corrosion. Be sure not to drop water or foreign material on the connector when disconnecting it.

4. Disconnect the TR switch connector.
5. Remove the clip and disconnect the selector cable.

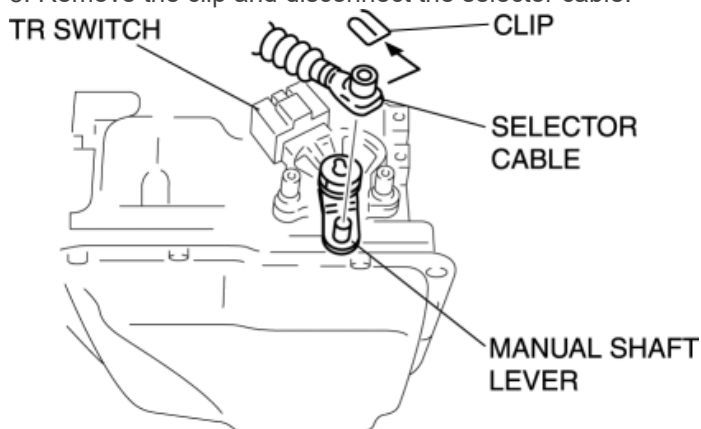

#### CAUTION:

- Do not use an impact wrench. Hold the manual shaft lever when removing the manual shaft nut, or the transaxle may be damaged.

6. Set the adjustable wrench as shown in the figure to hold the manual shaft lever.

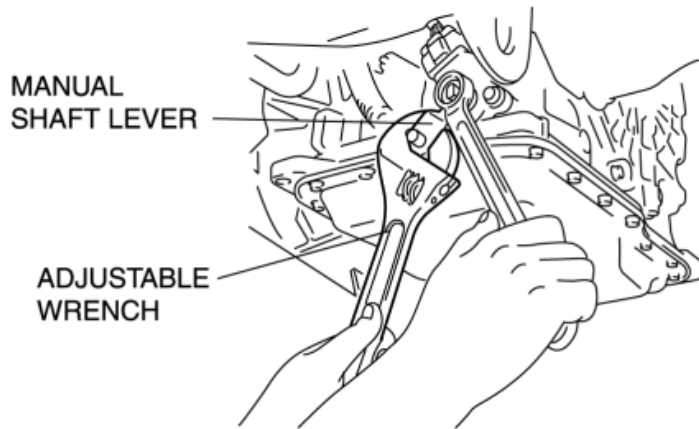

7. Remove the manual shaft nut and washer.

8. Remove the manual shaft lever.

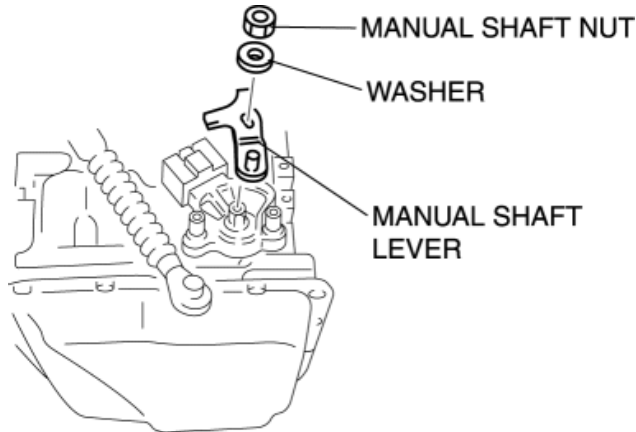

9. Remove the TR switch.

10. Rotate the manual shaft to the converter housing side fully, then return two notches to set the N position.

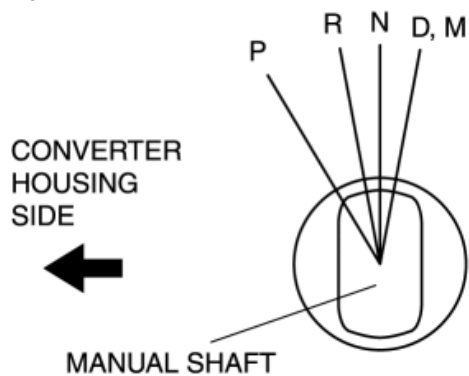

11. Turn the protrusion between the TR switch terminals B and C until the resistance becomes **750 ohms**.

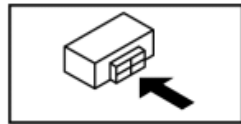
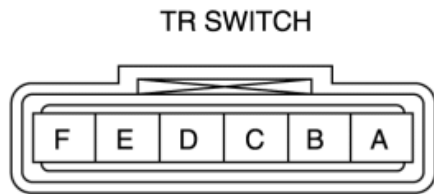
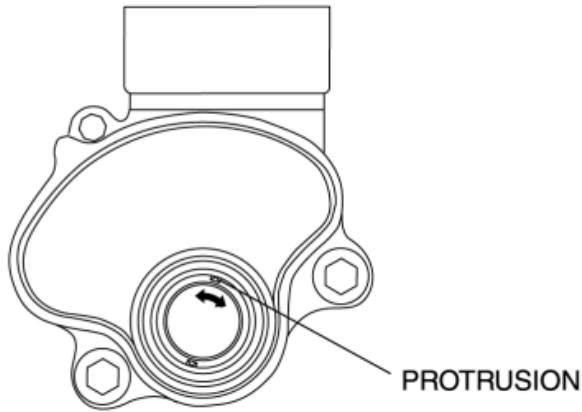

12. Install the TR switch while aligning the protrusion and groove as shown in the figure.

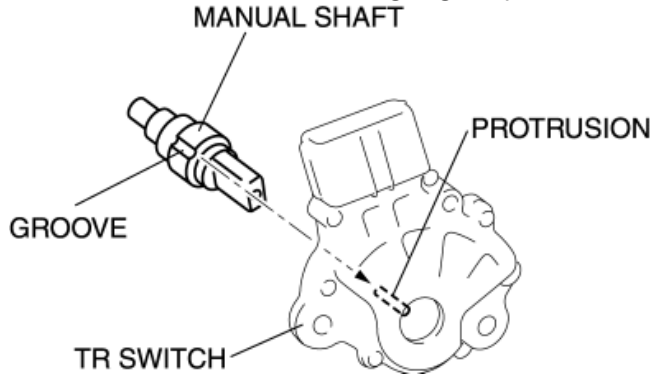

13. Hand-tighten the TR switch mounting bolts.

14. Inspect the resistance between the TR switch terminals B and C.

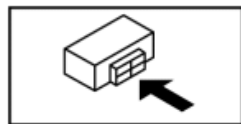
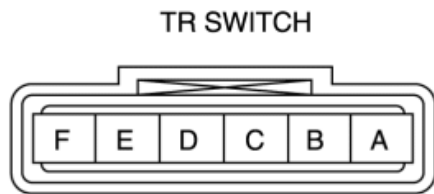

- If there is any malfunction, readjust the TR switch. (See [TRANSAXLE RANGE \(TR\) SWITCH ADJUSTMENT \[FN4A-EL\]](#).)

#### Resistance

- 750 ohms

15. Tighten the TR switch mounting bolts.

#### Tightening torque

- 8—11 N·m {82—112 kgf·cm, 71—97 in·lbf}

#### CAUTION:

- Do not use an impact wrench. Hold the manual shaft lever when removing the manual shaft nut, or the transaxle may be damaged.

16. Install the manual shaft lever and the washer.

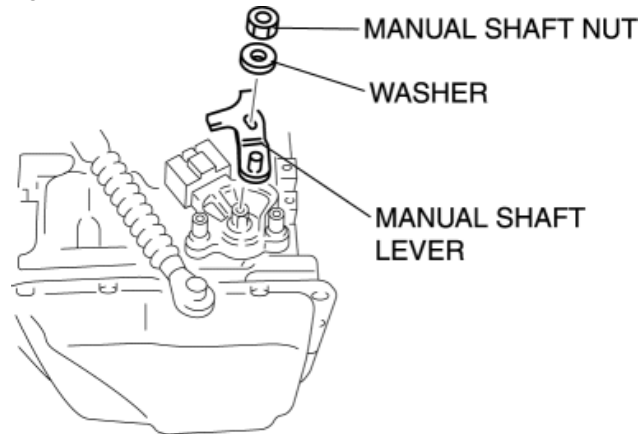

17. Set the adjustable wrench as shown in the figure to hold the manual shaft lever, and tighten the manual shaft nut.

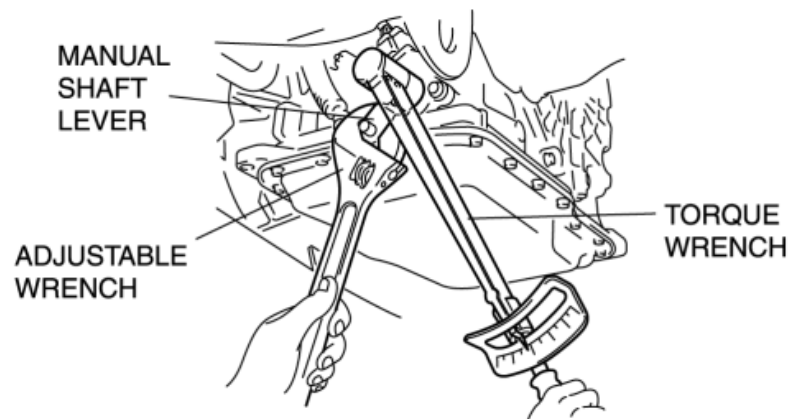

#### Tightening torque

- 31.4—46.1 N·m

{3.2—4.7 kgf·m, 23.2—33.9 ft·lbf}

18. Install the clip to the selector cable as shown in the figure.

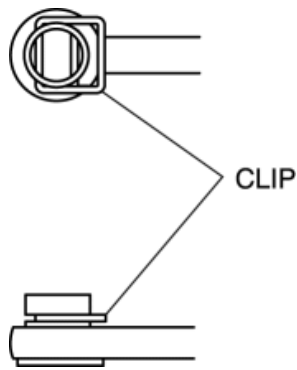

19. Shift the selector lever to P position.
20. Turn the manual shaft lever to P position.
21. Connect the selector cable.

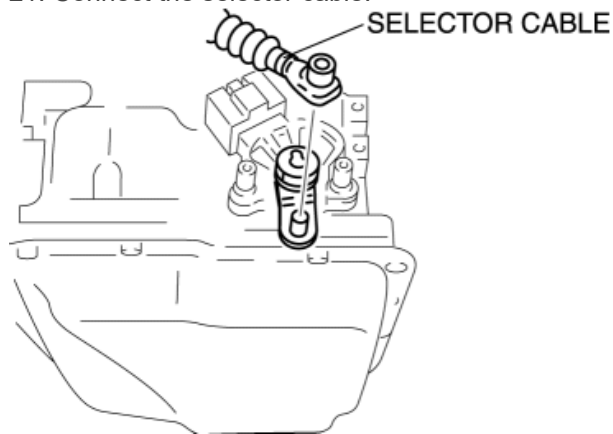

22. Inspect for continuity at the TR switch. (See [TRANSAXLE RANGE \(TR\) SWITCH INSPECTION \[FN4A-EL\]](#).)

- If there is any malfunction, readjust the TR switch. (See [TRANSAXLE RANGE \(TR\) SWITCH ADJUSTMENT \[FN4A-EL\]](#).)

23. Connect the TR switch connector.
  24. Install the under cover.
  25. Connect the negative battery cable.
  26. Install the battery duct and battery cover. (See [BATTERY REMOVAL/INSTALLATION \[LF, L3\]](#).)
  27. Inspect operation of the TR switch. (See [TRANSAXLE RANGE \(TR\) SWITCH INSPECTION \[FN4A-EL\]](#).)
- If there is any malfunction, readjust the TR switch. (See [TRANSAXLE RANGE \(TR\) SWITCH ADJUSTMENT \[FN4A-EL\]](#).)